



Engine		We c a	WP6G175E201
Rated Power	129 kW (173	/ 175) @ 2,000
Net Power	119 kW (160	/ 162) @ 2,000
Operating Weight			13,075 kg
Standard Bucket Size			2.3 m ³
Standard Breakout Force			124 kN
Standard Dump Clearance			2,889 mm

842H WHEEL LOADER

842H SPECIFICATIONS >>>

ENGINE

Emission Regulation	Tire 2 / Stage II
Manufacturer	WeiChai
Model	WP6G175E201
Rated Power	129 kW (173 hp / 175 ps) @ 2,000 rpm
Net Power	119 kW (160 hp / 162 ps) @ 2,000 rpm
Peak Torque	810 N · m @ 1,300-1,500 rpm
Displacement	6.75 L
Number of Cylinder	6
Aspiration	Turbocharged & Air-to-air intercooled

TRANSMISSION

Transmission Type	Planetary, power shift
Torque Converter	Double stage, four elements
Maximum Travel Speed, fwd	43 km/h
Maximum Travel Speed, rev	17.8 km/h
Number of Speed, fwd	2
Number of Speed, Rev	1

AXLES

Differential Front Type	Conventional
Differential Rear Type	Conventional
Axle Oscillation	±10.5°

STEERING

Steering Configuration	Articulated
Steering Relief Pressure	17.2 MPa

BRAKES

Service Brake Type	Caliper discs brake
Service Brake Actuation	Air over hydraulic
Parking Brake Type	Drum
Parking Brake Actuation	Mechanical

HYDRAULIC SYSTEM

Main Pump Type	Gear
Main Relief Pressure	19 MPa
Raise	5.5 s
Dump Time	1.1 s
Float Down Time	3.0 s
Fastest Total Cycle Time	9.6 s

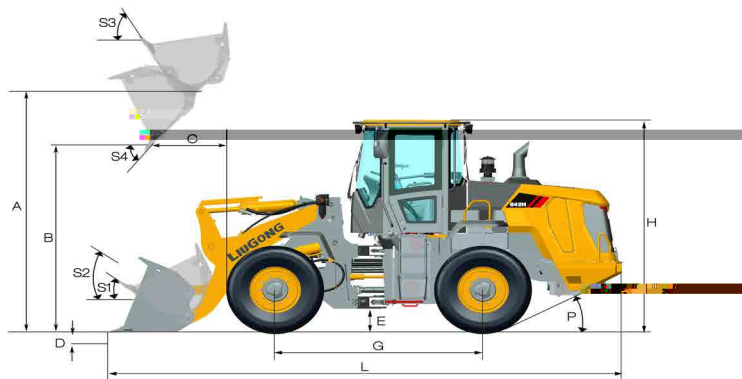

LOADER ARM PERFORMANCE with Standard Bucket 2.3 m³

Tipping Load - Straight (ISO 14397-1:2007)	9,600 kg
Tipping Load - Full Turn (ISO 14397-1:2007)	8,500 kg
Bucket Breakout Force	124 kN
A Maximum Hinge Pin Height	3,809 mm
B Dump Clearance at Full Height Discharge	2,889 mm
C Dump Reach at Full Height Discharge	1,110 mm
D Maximum Digging Depth, Bucket Level	45 mm
S ₁ Rollback at Ground Level	43°
S ₂ Bucket Rollback at Carry	49°
S ₃ Bucket Rollback at Maximum Height	61°
S ₄ Maximum Dump Angle at Full Height	45°

BUCKET PERFORMANCE

Reference Bucket	2.3-4.0 m ³
------------------	------------------------

DIMENSIONS

E Ground Clearance	384 mm
G Wheelbase	3,000 mm
H Cab Height	3,300 mm
J Wheel Tread	1,950 mm
K Width Over Tires	2,480 mm
L Length with Bucket Down	7,573 mm
M Turn Angle, Either Side	40°
P Rear Angle of Departure	28°
R ₁ Turning Radius, Bucket Carry	5,983 mm
R ₂ Turning Radius, Outside of Tire	5,393 mm
W Width Over Bucket	2,756 mm

TIRES

Tire Size	20.5-25 PR16 L-3 TT
-----------	---------------------

OPERATING WEIGHTS

Operating Weight	13,075 kg
------------------	-----------

SERVICE CAPACITY

Fuel Tank	190 L
Engine Oil	18 L
Cooling System	40 L
Hydraulic System	115 L
Transmission and Torque Converter	45 L
Axles, Each	22 L

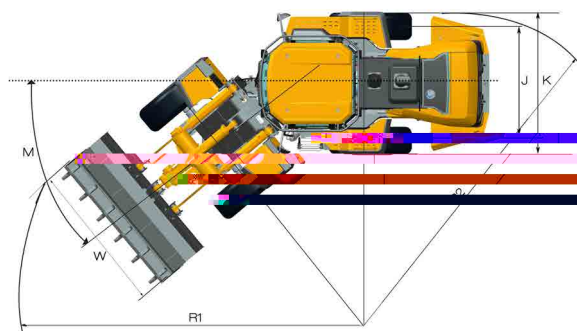

Guangxi Liugong Machinery Co., Ltd.

No. 1 Liutai Road, Liuzhou, Guangxi 545007, PR China
T: +86 772 3886124 E: overseas@liugong.com
www.liugong.com

Specifications and designs are subject to change without notice. Machines shown may include optional equipment. Liugong standard and optional equipment may vary from region to region. Please consult your Liugong dealer for information specific to your area. Engine power kW is converted to horsepower (1 kW=1.3596 ps and 1 kW=1.3410 hp) in this file.

02/2022 Designed by LiuGong
Replace the previous versions of 06/2019